

Theoretical Background of the Vertical Sounding from TIROS-N Satellite Series

Tadao Aoki*

Abstract

In Meteorological Satellite Center (MSC) the vertical sounding of temperature, moisture and other atmospheric parameters from TIROS-N satellite series, launched by the United State of America, is now operational beginning from January 1981. The products from the vertical sounding system involve the vertical temperature profile, vertical precipitable water profile, total ozone amount, sea or ground surface temperature, the cloud parameters such as the cloud top height, cloud amount and cloud emissivity.

This article briefly summarizes the theoretical background of the data processing system of MSC for the retrieval of these atmospheric parameters. For the hardware system of TIROS-N satellite series see Schwalb (1978).

1. Retrieval of the cloud parameters and clear radiances

The most outstanding point of the vertical sounding system of MSC is the cloud parameter determination and the clear radiance retrieval. About 300-450 pixels of AVHRR are contained within a HIRS spot. In MSC system the cloud amount in each HIRS spot is calculated by counting the number of the AVHRR pixels of cloudy radiance. Here, the cloudy radiance is defined as the radiance that is smaller than a critical value. The critical value of the AVHRR radiance is given by reducing, by some amount which slightly varies with latitude, the initial guess field of the AVHRR clear radiance given every $1 \times 1^\circ$ latitude/longitude areas.

The AVHRR clear radiance is calculated from the initial guess field of the surface temperature and the atmospheric temperature and moisture. The surface temperature is given for every $1 \times 1^\circ$ latitude/longitude areas, which has been compiled by the objective analysis method using the surface temperature data obtained from last soundings.

The atmospheric temperature and moisture fields

are given for every $5 \times 5^\circ$ latitude/longitude areas, compiled from the NMC (National Meteorological Center of America) data acquired through GTS (Global Telecommunication System). In future the temperature and moisture profiles obtained by the vertical sounding system of MSC may also be used. At present such a module has not yet been developed. In MSC system the temperature field is given for 33 pressure levels from the surface to 0.3 mb. On the other hand we can retain the temperatures of only 6 or 7 pressure levels from NMC data. Thus the temperatures at other pressure levels between the surface and 20 mb are interpolated from NMC data by Lagrange's interpolation method and for other higher pressure levels between 20 and 0.3 mb the temperature values are given by the following regression equation :

$$T_j = \sum_i \alpha_i T_i, \quad (1)$$

where T_m is the temperature at the m -th level and α is the regression coefficient, which is determined from the rocket sonde data. In Eq. (1) the summation is performed over the levels under 20 mb for which the temperature values have already been

*Meteorological Satellite Center.

given.

The field of the surface temperature and the atmospheric temperature and moisture are updated twice a day. The initial guess field of AVHRR clear radiance is also calculated twice a day. At the same time the clear radiance of all HIRS channels are also calculated for $5 \times 5^\circ$ latitude/longitude areas. This latter data is used in the next step as the initial values for the clear radiance retrieval.

In the process of the cloud amount determination, we also obtain the maximum and minimum AVHRR radiance and two kind of averages of the AVHRR radiance; the averages over all pixels and over only cloudy pixels of AVHRR contained within each HIRS spot. These data are used for the clear radiance retrieval (for the details see Aoki, 1980 a, 1982). Also used are these data for the estimation of the cloud top height and cloud emissivity as described later.

In the navigation of the AVHRR radiance data within each HIRS spot for the calculation of the cloud amount and others described above, it is necessary to know what pixel of AVHRR belongs to a HIRS spot. For the details of the determination of the relative position of the AVHRR pixel and HIRS spot see Aoki (1980 b) and Aoki and Nakajima (1981). Since the relative position of the AVHRR and HIRS pictures are unchanged through the operation of a satellite, they are determined only once for each satellite of TIROS-N satellite series.

2. Retrieval of the vertical temperature and moisture profiles

2.1 The formulation of the retrieval equation

Denoting the atmospheric temperature at the j -th pressure level or the precipitable water from the top of the atmosphere to the j -th level, by X_j , we calculate it by the following equation :

$$X_j = \sum_i C_{ji}(\mu) R_i(\mu), \quad (2)$$

where C_{ji} is the regression coefficient and R_i the clear radiance of the i -th channel except for $i=0$, where $R_0(\mu)=1$. The regression coefficient is determined from about 500 of coincident data of ra-

diasonde data, X , and satellite data, R . μ is the inverse of the cosine of the zenith angle θ' ($\mu=1/\cos\theta'$) of the line of sight from the scan spot on the surface to the satellite. θ' is a function of the scan angle θ . θ and θ' is not equal because the earth surface is not flat.

Observations by HIRS is made at 56 scan spots in the scan angle range of ± 49.5 degrees. As the μ changes with the scan step we have to prepare many number of the value of the coefficient C depending on the scan step, i. e., μ . However, considering the fact that according to the theoretical study of this author (unpublished) the clear radiances vary only a very small range of less than 10 percent, we can expect that μ -dependence of C is also weak so that it can be parameterized with a simple function of μ . One of the simplest form of C may be given by

$$C_{ji} = K_{ji} + C_{ji}' \Delta\mu, \quad (3)$$

$$\Delta\mu = \mu - \mu_r, \quad (4)$$

where μ_r is the μ at a reference step angle, K_{ji} is the $C_{ji}(\mu)$ at $\mu=\mu_r$ and constant independent of μ :

$$K_{ji} = C_{ji}(\mu_r). \quad (5)$$

It should be noted that since $R_0 (=1)$ is independent of μ , C_{j0} may also be independent of μ , however, we assumed the same functional form as Eq. (3).

Now, the number of the parameters of C_{ji} that must be determined for each value of j has been reduced to $2(L+1)$; that is, they are the K_{ji} and C_{ji}' ($i=0, \dots, L$). To obtain the sufficiently stable solution C_{ji} we must hopefully have about 20 $(L+1)$ or more number of the coincident data of X (observed by radiosonde) and R (observed by radiometer) and they, at the same time, should evenly be distributed over various values of the step angle. Considering this fact it is desired to reduce further the number of the parameters to be determined.

According to the so-called Minimum Information Method (MIM) (see, e. g., Smith et al. 1972) the retrieval of the atmospheric temperature or moisture profile is obtained by the same functional form as the Eq. (2) except that the coefficient C is now deter-

mined theoretically from the weighting function. The weighting function is, in turn, obtained from the transmission function τ , being given in the form :

$$\tau = \exp\left[-\int_0^p k\mu dp\right], \quad (6)$$

where p is the pressure and k is the absorption coefficient. If we plot τ against the vertical axis

$$z = 1n(p), \quad (7)$$

the vertical profile of τ for a slant path is roughly represented by shifting, by amount $\ln(\mu)$, the profile of τ for the vertical path toward the direction of z . Accordingly, it is expected that the function C for a slant path can also be obtained from the C for the vertical (see Appendix).

From this consideration we approximate the curve of $C_{jt}(\mu)$ by K_{jt} with slightly shifting toward the direction of z as follows :

$$C_{jt}(z_j, \mu) = K_{jt}(z_j + \delta_i), \quad (8)$$

where δ is the amount of the shift and assumed to be proportional to $\Delta\mu$:

$$\delta_i = \eta_i \Delta\mu, \quad (9)$$

where η_i is the constant depending only on the channel number. It should be noted here that only for C_{j0} the formula of the Eq. (8) was assumed.

Now the number of parameters that must be determined reduced from $2(L+1)$ to $L+3$: They are K_{jt} ($i=1, \dots, L$), η_i , C_{j0} (μ_r) and C_{j0}' . Thus, the Eq. (2) is rewritten in the form :

$$X_j = C_{j0} + C_{j0}' \Delta\mu + \sum_{i=1}^L K_{jt}(z_j + \delta_i) R_i(\mu), \quad (10)$$

2.2 The procedure to determine the regression coefficient

Since the value of δ_i in Eq. (8) is small we approximate $K_{jt}(z_j + \delta_i)$ by, with using the Eq. (9) :

$$K_{jt}(z_j + \delta_i) \approx K_{jt}(z_j) + \frac{\partial K_{jt}}{\partial z} \eta_i \Delta\mu. \quad (11)$$

The Eq. (10) can now be written in the form :

$$X_j = \sum_{i=0}^L K_{jt} R_i(\mu) + \sum_{i=0}^L D_{jt} \eta_i Q_i(\mu), \quad (12)$$

where

$$\left. \begin{aligned} K_{j0} &= C_{j0} \\ D_{j0} &= C_{j0}' \\ D_{jt} &= \partial K_{jt} / \partial z_j (i \neq 0) \\ \eta_0 &= 1 \\ Q_0 &= \Delta\mu \\ Q_i &= R_i \Delta\mu (i \neq 0) \end{aligned} \right\} \quad (13)$$

i) Zeroth order solution of K_{jt}

We will determine $K_{jt}(z_j)$ and η_i under the constraints that K_{jt} minimizes the following quantity :

$$\sigma_\eta = \sum_j [X_{jt}(\text{cal}) - X_{jt}(\text{obs})]^2, \quad (14)$$

and η_i minimizes the following quantity :

$$\sigma_\eta = \sum_j \sum_i [X_{jt}(\text{cal}) - X_{jt}(\text{obs})]^2, \quad (15)$$

respectively. Here l denotes the number of the observed data set of R and X , and the summation is performed over all of the data set. $X_{jt}(\text{cal})$ and $X_{jt}(\text{obs})$ denote the calculated and observed quantities X_j for the l -th data set.

If we approximate $\partial K_{jt} / \partial z$ by, e. g.,

$$\frac{\partial K_{jt}}{\partial z} \approx \frac{K_{j+1,t} - K_{j-1,t}}{z_{j+1} - z_{j-1}}$$

we can obtain the simultaneous linear equation system of K and η by differentiating the Eq. (14) by K_{jt} and the Eq. (15) by η_i , respectively. However, in such method the formulation becomes somewhat complicated. Thus, instead, we adopt the following approximation : First we use only the data where $\Delta\mu$ is nearly zero and we neglect the second term of Eq. (12). Substituting this approximation into the Eq. (14) and differentiating it by K_{jm} we have

$$\frac{\partial \sigma_j}{\partial K_{jm}} = 2 \sum_i [K_{jt} R_{it} - X_{jt}] R_{mt} = 0, \quad (16)$$

from which we obtain the zeroth order approximation of K as, in matrix form,

$$K^{(0)} = (XR^t)^{-1}, \quad (17)$$

where the superscript t denotes the matrix transposition. It should be noted again that in Eq. (17) only the data of $\Delta\mu$ nearly zero are used.

Now let us approximate D_{jt} by

$$D_{jt} = \frac{\partial K_{jt}^{(0)}}{\partial z} \quad (18)$$

and substitute the Eqs. (12) and (13) into (15). Differentiating the Eq. (15) by η we obtain

$$\frac{\partial \sigma_\eta}{\partial \eta_n} = 2 \sum_j \sum_i [\sum_i K_{jt} R_{it} + \sum_i \eta_i D_{jt} Q_{it} - X_{jt}] D_{jn} Q_{it} = 0. \quad (19)$$

From this equation we have

$$\sum_i \eta_i S_{in} = Y_n, \quad (20)$$

where

$$\left. \begin{aligned} S_{in} &= [DD^t]_{ni} [QQ^t]_{in} \\ Y_n &= [D^t XQ^t - DK^t RQ^t]_{nn} \end{aligned} \right\} \quad (21)$$

Since we have L of similar equations as (20) for various value of η we obtain

$$\eta = S^{-1}Y. \quad (22)$$

On the other hand, by differentiating the Eq. (14) by K_{jn} ($j=1, \dots, N, n=0, \dots, L$) we obtain

$$\sum_i [\sum_i K_{jt} R_{it} + \sum_i D_{jt} \eta_i Q_{it} - X_{jt}] R_{ni} = 0. \quad (23)$$

By substituting η from the Eq. (22) into (23) we can obtain the simultaneous linear equations of $(L+1)N$, to solve the same number of K_{jn} . However, this linear equation system is also complicated. Then, instead, we obtain an approximate solution sequentially as follows :

ii) Zeroth order solution of η , $\eta^{(0)}$

By approximating K in Y appeared in Eq. (21) by $K^{(0)}$ we obtain the zeroth order solution of η as

$$\eta^{(0)} = S^{-1} [D^t XQ^t - D(K^{(0)})^t RQ^t]. \quad (24)$$

iii) First order solution of K , $K^{(1)}$

Substitution of $\eta^{(0)}$ into the Eq. (23) gives us the first order solution of K :

$$K^{(1)} = [XR^t - U][RR^t]^{-1}, \quad (25)$$

where

$$U_{jn} = \sum_i D_{jt} \eta_i^{(0)} [QR^t]_{in}. \quad (26)$$

By the iterative calculation of K and η using the equations from (18) through (26) we may have accurate solutions, however, in the present system of MSC we are using $\eta^{(0)}$ and $K^{(1)}$ given in Eqs. (24) and (25), respectively, as the final solution.

3. The regression coefficients for the surface temperature and the total ozone amount

In contrast with the water vapor we estimate only the total amount of ozone because the number of the channel to obtain the information of the ozone profiles is a few. For the case of the total ozone amount and the surface temperature, the η -technique, described in the preceding section, can not be used so that the Eq. (3) was adopted. That is, the surface temperature or ozone amount is calculated by the following equation :

$$X = \sum_i [K_i + C_i' \Delta\mu] R_i. \quad (27)$$

The coefficients K_i and C_i' are determined so as to minimize the similar quantity as σ , Eq. (14). Thus, differentiating this quantity by K_i and C_i' we obtain

$$KRR^t + C'QR^t = XR^t \quad (28)$$

and

$$KRQ^t + C'QQ^t = XQ^t, \quad (29)$$

respectively.

From these two equations we have

$$C' = BA^{-1}, \quad (30)$$

$$K = [XR^t - C'QR^t][RR^t]^{-1}, \quad (31)$$

where

$$A = QQ^t - QR^t(RR^t)^{-1}RQ^t, \quad (32)$$

$$B = XQ^t - XR^t(RR^t)^{-1}RQ^t. \quad (33)$$

4. Cloud amount, cloud top height and cloud emissivity

As has already been described in the preceding section 2, the partial cloud amount within each HIRS spot is determined by counting the AVHRR pixels whose radiance are smaller than the critical value I_{cr} . Since a HIRS spot contains only about 400 pixels of AVHRR, the accuracy of the cloud amount is at most 0.25%. Moreover, as the AVHRR pixels do not cover the area of a HIRS spot completely, the accuracy of the cloud amount will be less than this value.

The cloud top height is determined by the method of Smith and Platt (1978). According to the method of Smith and Platt (1978) the cloud top height is determined by finding the value of the pressure p_c that satisfies the following equation :

$$\frac{R(\nu_1) - I(\nu_1)}{R(\nu_2) - I(\nu_2)} = \frac{\int_0^{p_c} \epsilon_T(\nu_1, p) \partial B(\nu_1, p) / \partial p dp}{\int_0^{p_c} \epsilon_T(\nu_2, p) \partial B(\nu_2, p) / \partial p dp}, \quad (34)$$

where ν_1 and ν_2 denote the different two channels of HIRS : In the present system of MSC they are 7 and 8th channels.

Another information of the cloud top height is obtained from the minimum radiance of AVHRR : As has been described in Aoki (1982) the minimum radiance of AVHRR upwells from the cloud whose emissivity is likely unity. Thus the cloud top height is obtained from the apparent blackbody temperature of AVHRR minimum radiance, where the cloud top height is determined by using the retrieved temperature profile. The calculation of these two kinds of the cloud top are both performed and archived in the magnetic tape.

The cloud emissivity is defined as follow :

$$\epsilon_c = \frac{R - I_c}{R - I_c^*}, \quad (35)$$

where R is the clear radiance of AVHRR, which is determined by

$$R = \frac{\sum_i (1 - n_i) I_i(\max)}{\sum_i (1 - n_i)}, \quad (36)$$

where M is the number of the HIRS spots used for the retrieval of the clear radiance of HIRS channels, n_i the partial cloud amount in the i -th spot of HIRS and $I_i(\max)$ the maximum of the clear radiances of AVHRR which are larger than the critical radiance I_{cr} . I_c is the mean cloudy radiance of AVHRR averaged over cloudy pixels of AVHRR within the most cloudy spot of HIRS. I_c^* is the minimum radiance of AVHRR in the most cloudy HIRS spot.

5. TIROS-N data processing system

TIROS-N data processing system is comprised of two subsystems, the Operational Subsystem and Support Subsystem. The block diagram of the system is shown in Fig. 1.

(I) Operational Subsystem

This subsystem is comprised of the following components : Preprocessor, Cloud Information and Location Module(CIL), Atmospheric Parameter Retrieval Module(APRET), and Products Output System.

1) Preprocessor

The original HRPT (High Resolution Picture Transmission) data is acquired from 1600 BPI/2400 ft magnetic tape of four volumes at maximum and transmitted to the large computer (FACOM 230-75). The function of the Preprocessor is to calibrate the original HRPT data and store the calibrated AVHRR data and TOVS data into two files separately.

2) Cloud Information and Location Module (CIL)

CIL is one of the most important scientific modules in the TIROS-N data processing system of MSC. It determines the partial cloud amount in each HIRS spot using the AVHRR data. In addition it determines the maximum and minimum AVHRR radiances and the average radiances of AVHRR over cloudy area and over the whole area of a HIRS spot. Another function of the CIL is to determine the location of each HIRS spot from the

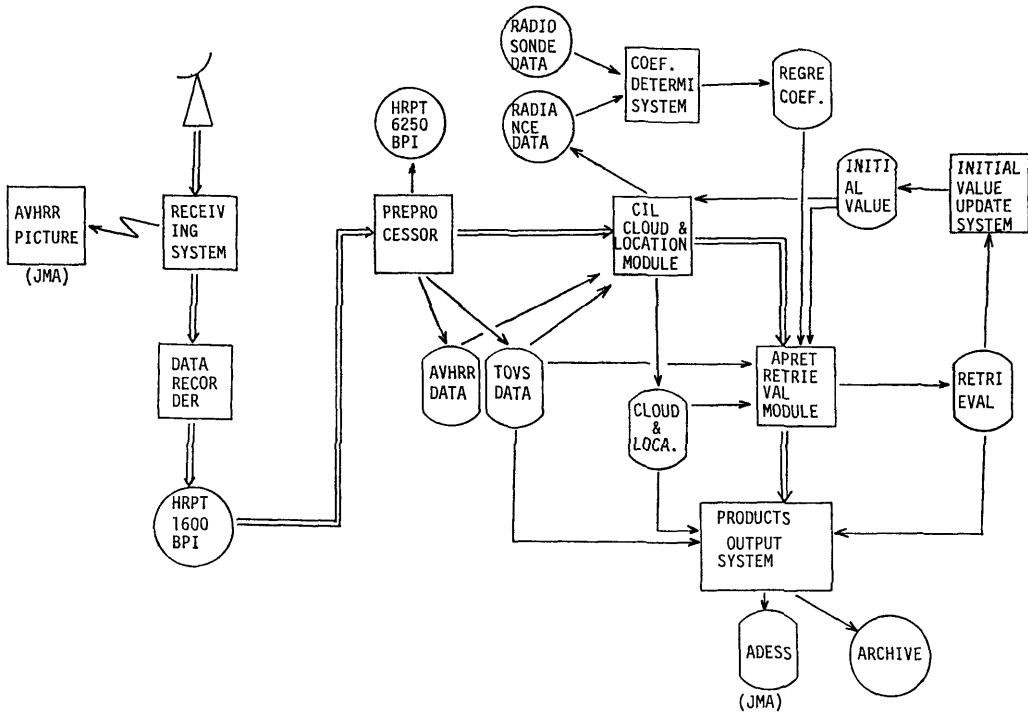

Fig. 1 Block diagram of the data processing system for the TIROS-N satellite series.

data of satellite track and satellite attitude. The latter information is obtained from the HIRS-AVHRR picture matching and AVHRR-land mark matching (see Aoki, 1980 b).

3) Atmospheric Parameter Retrieval Module (APRET)

The first function of APRET is to determine the clear radiance for every groups of M ($M=4$ at present) HIRS spots by the method of Aoki (1982) using the cloud informations obtained in CIL. Using the clear radiance thus determined the retrieval is performed to obtain the atmospheric temperature, sea or ground surface temperature, water vapor profile, total ozone amount. After the temperature profile is determined, we have the cloud top height, average cloud amount and cloud emissivity. APRET also performs a gross quality check on the retrieved atmospheric parameters.

4) Products Output System

This software component is comprised of two

modules: The function of the first module is to create the coded data to transmit to the Headquarters of Japan Meteorological Agency (JMA). These are the geopotential height and precipitable water in SATEM code (these data are used for the initial values of the numerical forecasting) and the atmospheric temperature and the relative humidity in TEMP SHIP code (these data are also used in the mapping for the forecast).

The function of another module in the Products Output System is to archive, in the magnetic tape, the data which are stored in the TOVS file, the Cloud Information and Location file and the Retrieval file as shown in Fig. 1. The details of these data in archive magnetic tape is shown in Table 1.

(II) Support Subsystem

Support Subsystem has two primary functions; to provide the Operational Subsystem with the regression coefficients and to update a twice per day initial value.

Table 1 The data in archive magnetic tape

<p>1. TOVS DATA Calibrated radiances of HIRS, SSU and MSU.</p> <p>2. CIL DATA (For every HIRS spots) Location on earth surface. Cloud amount. Averaged AVHRR radiance over whole area. Average AVHRR radiance over cloudy area. Maximum AVHRR radiance. Minimum AVHRR radiance. Initial guess of AVHRR clear radiance.</p> <p>3. APRET DATA Clear column radiance of HIRS and AVHRR. Temperatures at 1000, 850, 700, 500, 400, 300, 250, 200, 150, 100, 70, 50, 30, 20, 10 mb. Precipitable waters from the top of the atmosphere to 400, 500, 700, 850, 1000 mb. Sea or ground surface temperature. Total ozone amount. Mean cloud amount. Cloud top height by the method of Smith and Platt. Cloud top height from the minimum radiance of AVHRR radiance. Cloud emissivity.</p>
--

1) Coefficient Determination System

The function of this system is to determine the regression coefficient for the atmospheric temperature, water vapor, ozone amount and surface temperature from the radiance data and radiosonde or ship data.

2) Initial Value Update System

The function of this system is to update the initial values using the retrieval data from the Operational Subsystem and/or NMC (National Meteorological Center of America) data of atmospheric temperature. Here the "initial value" involves the AVHRR clear radiance field to be used in CIL for the determination of the critical value of the cloudy radiance of AVHRR and the clear radiance field of HIRS channels to be used for the initial values in the clear radiance retrieval in APRET.

6. Summary

The most outstanding point of the TIROS-N/TOVS data processing system in MSC, compared

to the others such as the system of NESS (National Earth Satellite Service of America), is that it uses the AVHRR data. This enables us to obtain the actual cloud amount in each HIRS spot. (In NESS system only the product of the actual cloud amount and the cloud emissivity is obtained.) This also enables us to determine the clear radiances accurately using the statistical method developed by Aoki (1982). At the same time the cloud informations such as the cloud top height and cloud emissivity are also obtainable. This will provide a very valuable informations to the cloud climate research.

According to the method of Aoki (1982) for the clear radiance retrieval, the accurate clear radiance is obtained for the cases where the average cloud amount is less than about 95 %, so that the soundings by HIRS channels are possible over very cloudy areas. From this reason in the present system of MSC, soundings are performed for every four spots of HIRS(M=4), that is, soundings are obtained in every 50-100 km distances. The number of the sounding points is about 16 times of that of NESS in unit area.

Appendix

In the plane parallel atmosphere, where the atmospheric temperature and atmospheric constituents are homogeneous in the horizontal, a monochromatic radiation $I(\mu)$, upwelling through a slant path of clear column atmosphere, can be written in the form :

$$I(\mu) = B(T_s) \tau(p_s, \mu) - \int_0^p B(T) \frac{\partial \tau}{\partial p} dp. \quad (A1)$$

where B is the planck function and T the temperature. s refers to the values at the surface. τ is given by the Eq. (6) in the text. μ varies only in the small range 1-2. On the other hand, τ can be approximated in the small range of pressure, e. g. $p-2p$, as

$$\tau = \exp(k' \mu p), \quad (A2)$$

where k' is constant in the range $p-2p$. This formula suggests that the function τ for a slant path of μ is approximately represented by shifting the τ for the vertical path by an amount $\ln(\mu)$ toward the vertical, when τ is plotted against the axis $z = \ln(p)$.

Now, according to the Minimum Information Method, the temperature or moisture profile is obtained by the following equation :

$$X = \Gamma^t [\Gamma^t + \gamma E]^{-1} (R - R^0) + X^0, \quad (A3)$$

where Γ is the weighting function matrix, γ the constant, E the unit matrix, R^0 the initial value of R and X^0 the initial value of X . The superscript t denotes the matrix trasposition. Γ is given by

$$\Gamma_{ji}(z_j) = \frac{\partial B_{ji}(z_j)}{\partial T} \frac{\partial \tau}{\partial p}. \quad (A4)$$

If $\partial B/\partial T$ is assumed to be constant, the weighting function for a slant path can be represented approximately by the weighting function for the vertical path shifted by $\ln(\mu)$ toward the direction z . Finally, it is also expected that the coefficient $\Gamma^t [\Gamma^t + \gamma E]^{-1}$ for a slant path can be approximated by that for the vertical, shifting toward the vertical by some amount.

References

Aoki, T., 1980a : A statistical method to retrieve the clear radiance from cloud-contaminated radiances. *J. Meteor. Soc. Japan*, 58, 58-66.
 _____, 1980b : A method for matching the HIRS /2 and AVHRR pictures of TIROS-N satellites. *Meteor. Satellite Center Tech. Note*, No. 2, 15-26.
 _____, 1982 : An improved method to retrieve the clear column radiance from partially cloudy spots of radiometer on board satellite. *J. Meteor. Soc. Japan* (to be published).
 _____ and S. Nakajima, 1981 : On misalignment between HIRS and AVHRR pictures of NOAA-6 meteorological satellite. *Meteor. Satellite Center Tech. Note*, No. 4, 63-67.
 Schwalb, A., 1978 : The TIROS-N/NOAA A-G satellite series. *NOAA Tech. Memo. NESS 95*.
 Smith, W. L., H. M. Woolf and H. E. Fleming, 1972 : Retrieval of atmospheric temperature profiles from satellite measurements for dynamical forecasting. *J. Appl. Meteor.*, 11, 113-122.
 Smith, W. L. and C. M. R. Platt, 1978 : Comparison of satellite-deduced cloud heights with indications from radiosonde and ground-based laser measurements. *J. Appl. Meteor.*, 17, 1976-1802.

タイロスNシリーズからの鉛直分布算出における理論的背景

青木 忠生
 気象衛星センター システム管理課

米国の気象衛星タイロスNシリーズを使つての温度や水蒸気あるいはその他の気象学的パラメーターの鉛直分布算出が、1981年1月から気象衛星センターで現業化されている。製品としては鉛直温度分布、鉛直可降水量分布、オゾン全量、海面及び地面温度、雲頂高度、雲量、雲の射出率などである。

本論文では、本センターにおける上記のような鉛直分布算出の理論的背景を概説する。なおタイロスN衛星のハードウェアについては Schwalb (1978) の報告書を参照されたい。